

## OVERHEAD/GANTRY CRANE BLOCKS

Light duty blocks

### Two Sheaves Block

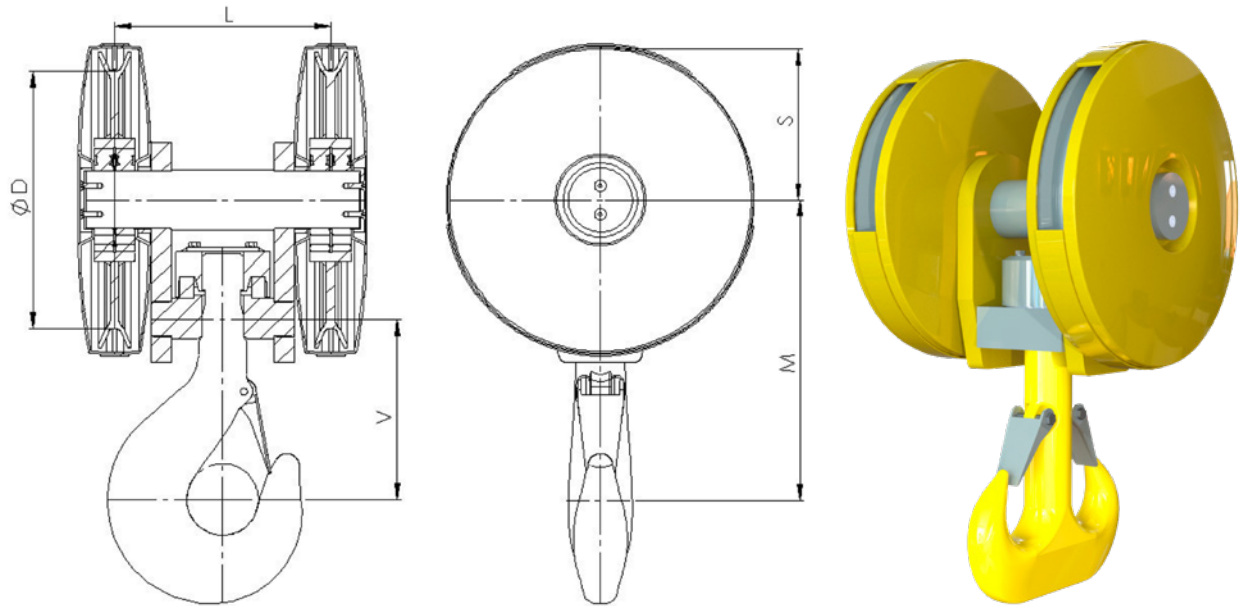

- WLL: from 4t to 64t.
- Hook: Single or Ramshorn. Forged and heat treated fully machined with nut & crosshead. Max size: 16 acc to DIN15400. Material grades: carbon (P) or alloy (V).
- Sheave: 2 (4 falls). Cold Laminated or Technical Plastic. Max size 450mm (inner diameter).
- Bearing: axial for hook assembly + roller/ball for sheaves.
- Coating Protection: fully painted inside & outside.
- Certificate: EN10204-2.1. Load Test & FAT upon request.

LIGHT DUTY BLOCKS   TWO SHEAVES BLOCK									
Overall dimensions (mm)							WLL (t) 1Bm/M3		Weight
Hook No	Ø Wire rope	ØD Sheave	L	V	M	S	P	T	kg
1,6	7	160	162	140	240	105	4	6,3	18
2,5	10	200	194	155	265	131	6,3	10	30
4	15	280	222	175	320	180	10	16	60
5	15	280	242	195	335	180	12,5	20	66
6	16	355	302	240	415	223	16	25	131
8	16	355	327	265	435	223	20	32	142
10	22	450	349	280	490	274	25	40	226
12	22	450	379	315	525	274	32	50	257
16	22	450	389	370	590	274	40	63	286