

FORGED ROV EYE HOOKS

Standard shank ROV eye hook

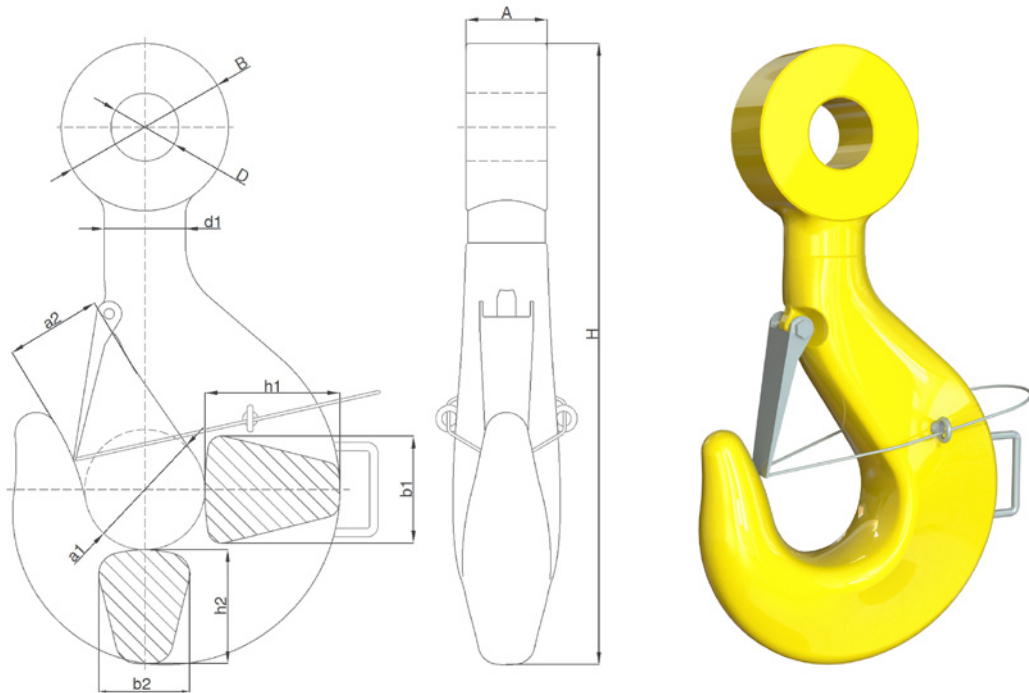

- WLL: from 80t to 1.000t.
- Hook forged and heat treated.
Fully bended with 100% grain orienting.
- Material: carbon, alloys and super alloys.
- Surface Protection & Coatings: upon request.
- Safety Factor: min. 4:1.
- Load Test: requested / recommended. ILO-3, FAT or Breaking Test available upon request.
- Certificate: EN10204-3.1. For 3.2, Mooring Accessory Cert (R4) with ABS and DNV upon request.

FORGED ROV EYE HOOKS STANDARD SHANK ROV EYE HOOK													Weight
Overall dimensions (mm)													
WLL (t)	MBL (t)	a1	a2	b1	b2	h1	h2	d1	A	D	B	H	kg
100	400	160	125	140	118	180	150	106	118	100	210	812	137
120	480	180	140	160	132	200	170	118	134	100	210	927	190
150	600	200	160	180	150	224	190	132	140	114	240	1052	272
200	800	224	180	200	170	250	212	150	150	137	290	1201	397
250	1000	250	200	224	190	280	236	170	170	147	310	1314	531
300	1200	280	224	250	212	315	265	190	190	158	330	1448	730
400	1600	315	250	280	236	355	300	212	205	184	380	1685	1033
500	2000	355	280	315	265	400	335	236	230	194	400	1871	1430
600	2400	400	315	355	300	450	375	265	255	215	450	2075	1998
800	3200	450	355	400	335	500	425	300	280	240	500	2294	2786
1000	4000	500	400	450	375	560	475	335	320	280	580	2450	3868
1250	5000	560	450	500	425	630	530	375	355	315	650	2810	5442
1550	6200	630	500	560	475	710	580	425	355	335	680	3060	7231
1800	7200	710	560	630	530	800	630	475	410	395	750	3430	9995

Smaller sizes upon request.

WLL working load limit using R4 material.

Tolerances: -0/+7% forging tolerance.

Eye dimensions (A,B,D) and other dimensions can be modified.