

FORGED ROV EYE HOOKS

Long shank ROV eye hook

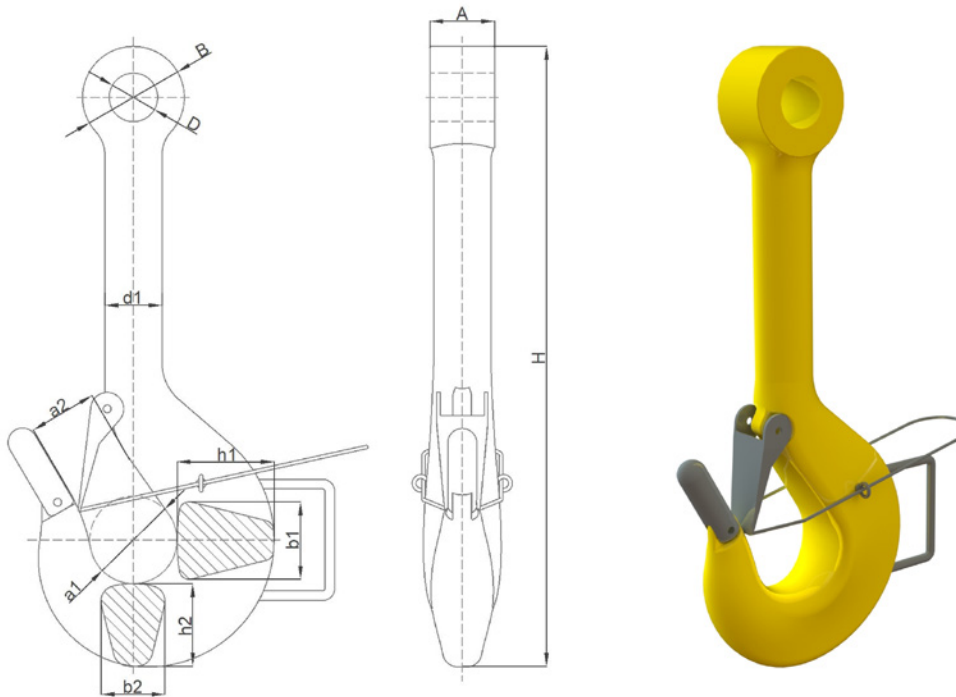

- WLL: from 10t to 600t.
- Hook forged and heat treated.
Fully bended with 100% grain orienting.
- Material: carbon, alloys and super alloys.
- Surface Protection & Coatings: upon request.
- Safety Factor: min. 4:1.
- Load Test: requested / recommended. ILO-3, FAT or Breaking Test available upon request.
- Certificate: EN10204-3.1. For 3.2, Mooring Accessory Cert (R4) with ABS and DNV upon request.

FORGED ROV EYE HOOKS LONG SHANK ROV EYE HOOK													
Overall dimensions (mm)												Weight	
WLL (t)	MBL (t)	a1	a2	b1	b2	h1	h2	d1	A	D	B	H	kg
100	400	160	125	140	118	180	150	106	118	100	210	1112	157
120	480	180	140	160	132	200	170	118	134	100	210	1277	220
150	600	200	160	180	150	224	190	132	140	114	240	1402	310
200	800	224	180	200	170	250	212	150	150	137	290	1551	450
250	1000	250	200	224	190	280	236	170	170	147	310	1664	630
300	1200	280	224	250	212	315	265	190	190	158	330	1848	840
400	1600	315	250	280	236	355	300	212	205	184	380	2085	1195
500	2000	355	280	315	265	400	335	236	230	194	400	2271	1635
600	2400	400	315	355	300	450	375	265	255	215	450	2475	2280

Smaller sizes upon request.
WLL working load limit using R4 material.
Tolerances: -0/+7% forging tolerance.
Eye dimensions (A,B,D) and other dimensions can be modified.