

EYE-CLEVIS SWIVEL

**CUSTOMIZATION
UPON REQUEST**

**COMPLETELY
WELDLESS**

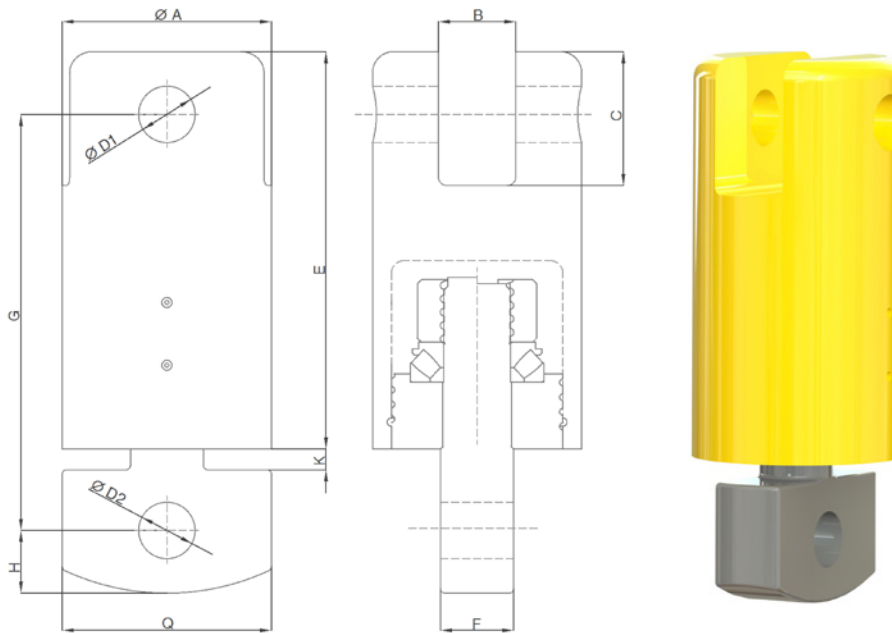

- WLL/SWL: from 50t to 1.500t.
- Hook forged, heat treated and machined, as per DIN15400 design or others upon request.
- Cover: free of weld.
- Material: carbon steel, alloy and super alloy. Most regular super alloy steel.
- Coating Protection: fully painted.
- Safety Factor: 4:1.
- Sealings: for onshore lifting, offshore topsite and subsea lifting & mooring.
- Load Test & MBL: requested and recommended.
- Certificate: EN10204-3.1. For 3.2, ILO-3, FAT or Breaking Test available upon request.

SWIVEL EYE-CLEVIS												
Overall dimensions (mm)												Weight
WLL (t)	A	B	C	D1	D2	E	F	G	H	K	Q	kg
200	500	185	320	135	135	950	175	995	150	50	500	1122
300	600	210	365	155	155	1100	200	1150	180	50	600	1910
400	650	216	410	180	180	1150	226	1200	205	50	650	2285

CRANE HOOKS

CRANE BLOCKS

SUBSEA HOOKS

SHACKLES

SWIVELS

CONNECTORS

ROPE ACCESSORIES